

SSI™ SNAPPY SADDLE™ DIFFUSERS

AFTS3100 91mm Tube

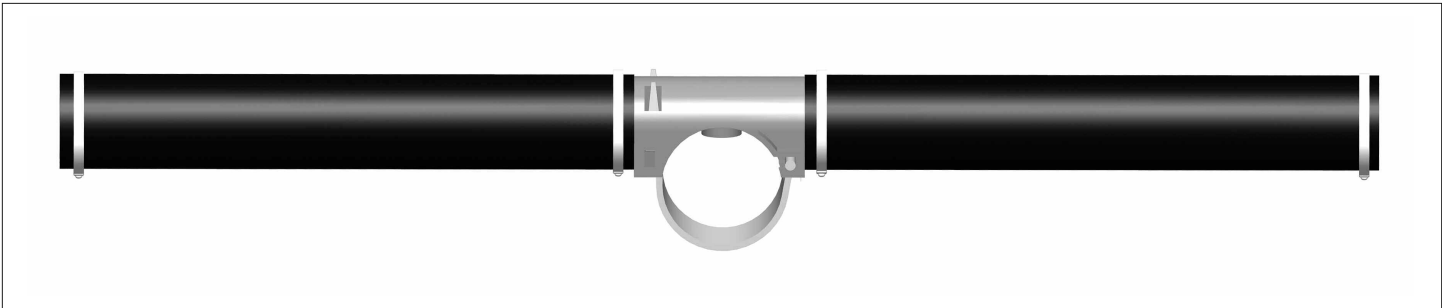

- Highest possible quality and technology means years of trouble-free efficient operation.
- Highest possible SOTE independently tested per ASCE and lowest possible headloss.
- Compression molded EPDM membranes have very tight wall thickness tolerances, a long track record and exhibit even air distribution and minimal shrinkage over time.
- One-piece lightweight but strong ABS body makes handling during installation very easy.
- Single orifice on top center line of pipe means little chance for a single diffuser failure to contaminate all diffusers.
- Experienced Engineering and Drafting staff with years of practice to assist you.
- Integral register prevents cantilevered diffusers from axial rotation around the header pipe.
- 212° F (100° C) temperature resistance and environmentally-friendly ABS body.
- Individual thermocouples in each cavity of compression mold = 100% quality control.
- Low membrane plasticizer content to reduce shrinkage and hardening, but enough to avoid creep.
- Multiple integral check valves keep your aeration piping system clean.
- In stock on 3 continents in 4 locations.

TUBE MEMBRANES

- PTFE
- fEPDM
- EPDM

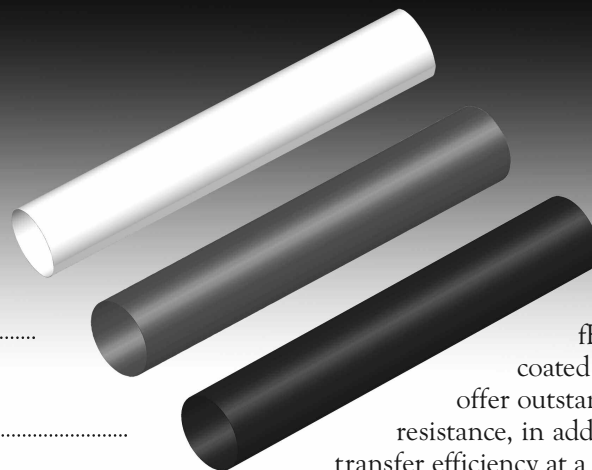

21st century special materials, such as PTFE, fEPDM, as well as reinforced and coated ultra fine bubble membranes offer outstanding chemical or fouling resistance, in addition to the highest oxygen transfer efficiency at a headloss you can live with.

Please see reverse for additional technical data



STAMFORD SCIENTIFIC
INTERNATIONAL
INCORPORATED

+1-845-454-8171 TEL
+1-845-454-8094 FAX

4 TUCKER DRIVE
POUGHKEEPSIE, NEW YORK 12603 USA
www.StamfordScientific.com
EMAIL: INFO@STAMFORDSCIENTIFIC.COM

SSI™ SNAPPY SADDLE™ DIFFUSERS

continued

AFTS3100 91mm Tube

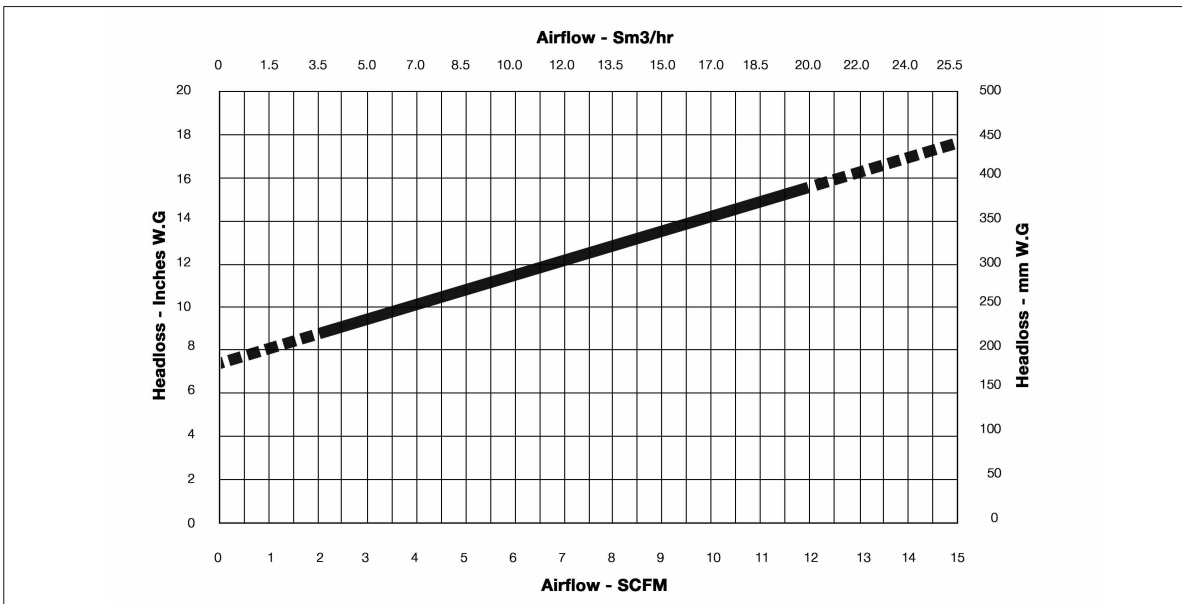
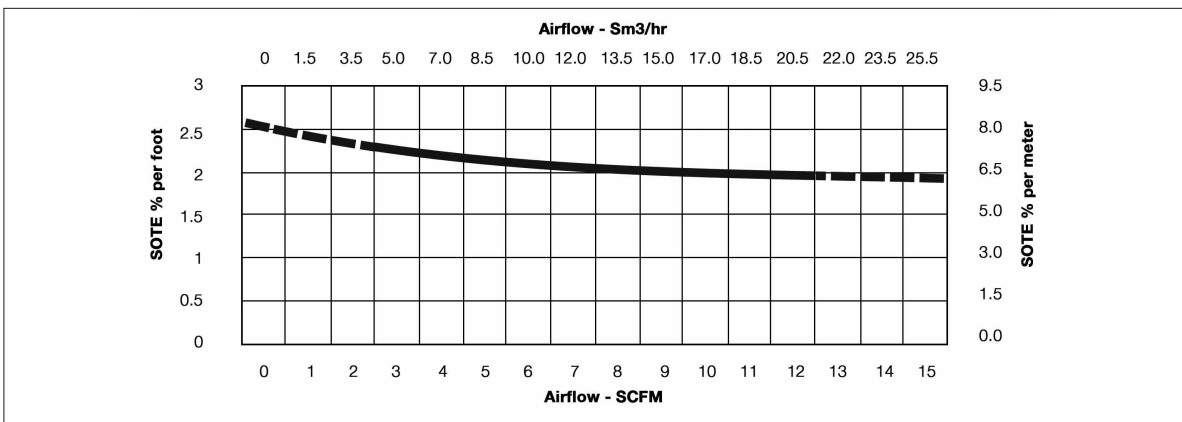
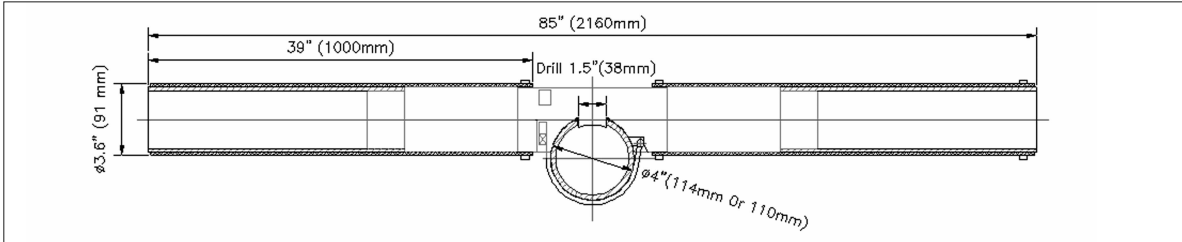

DESIGN FLOW	FLOW RANGE	ACTIVE SURFACE AREA	WEIGHT
2.0-13.0 SCFM (3.4 – 22 Sm ³ /hr)	0-16 SCFM (0-27.0 Sm ³ /hr)	4.75 ft ² /set (0.440 m ²)	10 lbs/set (4.5 Kg)



STAMFORD SCIENTIFIC
INTERNATIONAL
INCORPORATED

+1-845-454-8171 TEL
+1-845-454-8094 FAX

4 TUCKER DRIVE
POUGHKEEPSIE, NEW YORK 12603 USA
www.StamfordScientific.com
EMAIL: INFO@STAMFORDSCIENTIFIC.COM